

初級組  
Junior Division

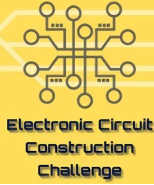

# 電子線路挑戰賽 2025

Electronic Circuit Construction Challenge 2025

## 報名表格 (Application Form)



香港科技大學  
THE HONG KONG  
UNIVERSITY OF SCIENCE  
AND TECHNOLOGY



Advancing Technology  
for Humanity



IEEE Hong Kong ED/SSC Joint Chapter

### 報名流程 Application Process

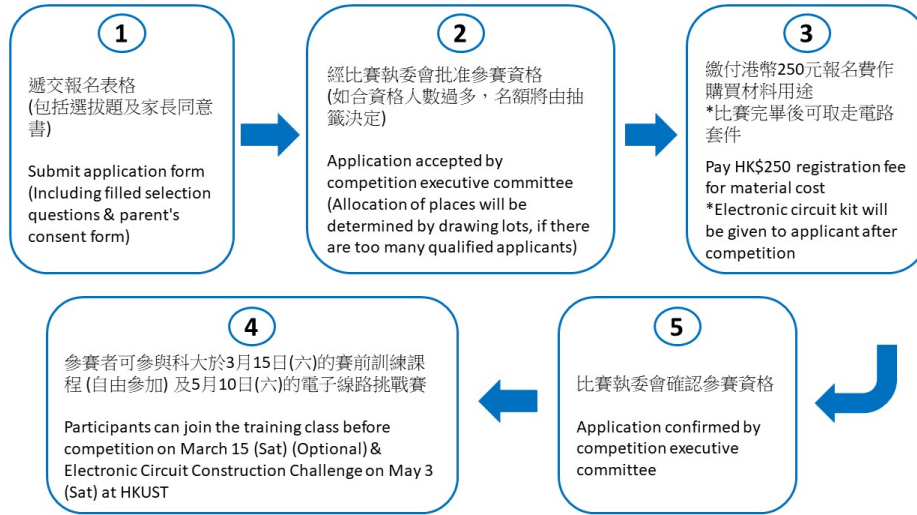

#### 參賽者資料 (Personal Information of Applicant)

姓名: \_\_\_\_\_ (中文) \_\_\_\_\_ (English) 性別: 男  女   
Name: \_\_\_\_\_ (English) Gender: M  F

出生日期: \_\_\_\_\_ 級別: \_\_\_\_\_ 學校: \_\_\_\_\_  
Date of Birth: \_\_\_\_\_ Grade: \_\_\_\_\_ School: \_\_\_\_\_

地址: \_\_\_\_\_  
Address: \_\_\_\_\_

電話: \_\_\_\_\_ 電郵地址: \_\_\_\_\_  
Contact Phone: \_\_\_\_\_ Email: \_\_\_\_\_

你是否參加 3 月 15 日 (星期六, 上午 9 時 45 分 至 下午 5 時正) 在科大舉辦的工作坊嗎? (自由參與) 是  否   
Will you be joining the workshop on March 15 (Sat, 9:45 am - 5:00 pm) at HKUST? (Optional) Yes  No

如果你通過學校申請, 請留下負責老師的聯絡資料

If you apply through your school, please write down the following contact information about your teacher-in-charge.

老師姓名 \_\_\_\_\_ 老師聯絡電話 \_\_\_\_\_  
Name of the teacher: \_\_\_\_\_ Teacher's contact number: \_\_\_\_\_

老師電郵地址 \_\_\_\_\_  
Teacher's email address: \_\_\_\_\_

## 選拔題 (Selection Questions)

選拔題有 6 條, 你的答案會決定參賽資格

There are 6 selection questions. Your qualification status will be determined by your answers to these questions.

從 Q1 至 Q4, 請勾選正確答案。

For Q1 to Q4, please tick the box with the correct answer.

### Q1

這個符號代表什麼?

What does this symbol represent?

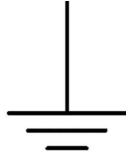

- a) 電池 Battery
- b) 接地 Ground
- c) 電容器 Capacitor

### Q3

下列哪一項/哪些表示垂直電線和水平電線的連接 (如有) ?

Which of the following(s), if any, shows the connection of vertical and horizontal wires?

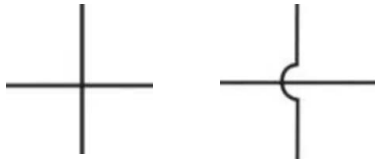

- a) 只有左邊的 Left-hand side only
- b) 兩者皆是 Both of them
- c) 兩者皆否 None of them

### Q5

請看下面的電路圖: Please look at the circuit diagram below:

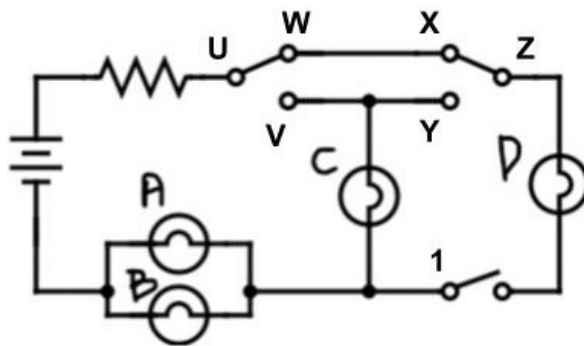

參考上面的電路圖, 當滿足下列條件時, 哪個/些燈泡 (A, B, C, D) 會亮起? 請勾選所有正確答案。

By referring to the circuit diagram above, which of the light bulbs (A, B, C, D) will be turned ON when the following conditions are met? Please tick all the boxes with the correct answer.

條件 Condition	A	B	C	D
開關制 1 閉合; U 與 V 連接; X 與 Z 連接 Switch 1 is closed; U & V are connected; X & Z are connected	<input type="checkbox"/>	<input type="checkbox"/>	<input type="checkbox"/>	<input type="checkbox"/>
開關制 1 斷開; U 與 V 連接; Y 與 Z 連接 Switch 1 is open; U & V are connected; Y & Z are connected	<input type="checkbox"/>	<input type="checkbox"/>	<input type="checkbox"/>	<input type="checkbox"/>
燈泡 A 燒壞, 開關制 1 閉合; U 與 V 連接; Y 與 Z 連接 Bulb A blows out; Switch 1 is closed; U & V are connected; Y & Z are connected	<input type="checkbox"/>	<input type="checkbox"/>	<input type="checkbox"/>	<input type="checkbox"/>

### Q2

這個符號代表什麼?

What does this symbol represent?

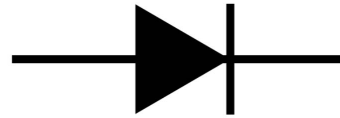

- a) 電阻 Resistor
- b) 發光二極管 Light-emitting diode
- c) 二極體 Diode

### Q4

哪一項/些電阻的類型沒有固定的電阻值?

Which type(s) of the resistor does NOT have a fixed resistance?

- (1) 330歐姆電阻 330 ohm resistors
- (2) 可變電阻 Variable resistors
- (3) 光敏電阻 Light-dependent resistor

- a) (1)
- b) (2) & (3)
- c) (1), (2) & (3)

## 選拔題 (Selection Questions)

### Q6

請回答以下兩個問題之一：

您可以使用文字（100 到 150 字）和/或插圖來作答。可使用中文或英文淺述。

Please answer one of the two questions below:

You may use text (100 to 150 words) and / or illustrations to explain your ideas. Your writing can be in Chinese or English.

醫療設備，如可穿戴健康監測器、血壓監測器和睡眠追蹤器，在我們的日常生活中被廣泛使用。它們不僅有助於改善病人護理和治療效果，還提升了整體醫療效率。

Healthcare devices, like wearable health monitors, blood pressure monitors and sleep trackers, are widely used in our daily lives. They not only help improve patient care and treatment effectiveness, but also the overall healthcare efficiency.

1)

請舉出一個電子技術如何融入當前醫療保健行業的例子。

Please provide an example of how electronics can be integrated into current healthcare industry.

2)

在醫療保健應用中融入電子技術，會遇到什麼挑戰？

What challenges arise when implementing electronics in healthcare applications?

我的答案:

My answer:

## 家長同意書 (Parent's Consent)

家長/監護人姓名  
Name of Parent / Guardian: \_\_\_\_\_

與參加者關係:  
Relationship with Applicant: \_\_\_\_\_

緊急聯絡電話:  
Emergency Contact : \_\_\_\_\_

- 本人同意子女參加是次活動，並確認其健康狀況良好。  
I agree to let my child participate in the activity and confirm that he/she is in good health.
- 本人明白並同意在是次活動期間所拍攝的照片和視頻將用於 IEEE 及香港科技大學未來活動的推廣材料。  
We understand and agree that photos and video images taken during activities and programs will be used for promoting or organizing activities of IEEE and HKUST.

家長簽署:  
Parent's Signature : \_\_\_\_\_

日期:  
Date: \_\_\_\_\_

[End 完]